

Horizontal Switch

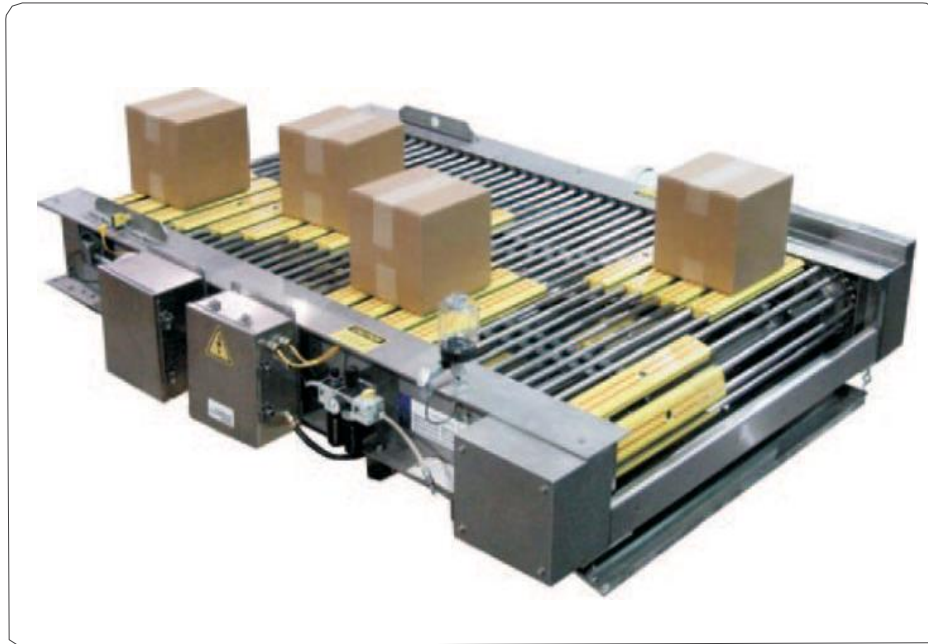

We are proud to present the original horizontal switch. For decades our customers have relied on it to be a reliable and irreplaceable component of their conveyor and distribution systems.

High speed continuous motion for sort or merge of product is what you get with our horizontal switch.

Multiple flow configurations are the fact of the matter with the flexible design of our switches, they can easily:

- Merge and / or divert across multiple lanes
- Combine from multiple to few lanes
- Distribute from fewer to multiple lanes
- Equal or surpass your production speed requirements.

A wide range of products are handled by the switches currently in service. We can easily meet the parameters below and if you require, exceed them as well.

- Small (3.00" long) to large (30.00" long)
- Light (ounces per ft.) to heavy (100# per ft.)
- Fragile (glass) to rugged (tractor ties)

Our high speed, flexible design and multiple in-feed and discharge lane capabilities make the horizontal switch best in class for high speed product handling applications.

The gentle touch of the horizontal switch is perfect for transferring soft or fragile products.

Operating Details and Benefits

- Ideal for bottling, food processing, durable goods, bakery and warehouse applications
- Over 250 configurations available to fit your application
- Flexible product handling in continuous flow operations
- Easy operation, maintenance and control
- State-of-the-art components for reliable, trouble-free operation
- Proven technology. Over 30 years, installed and continuously operating in systems worldwide
- High speed, up to 300 FPM, merging and/or sorting.



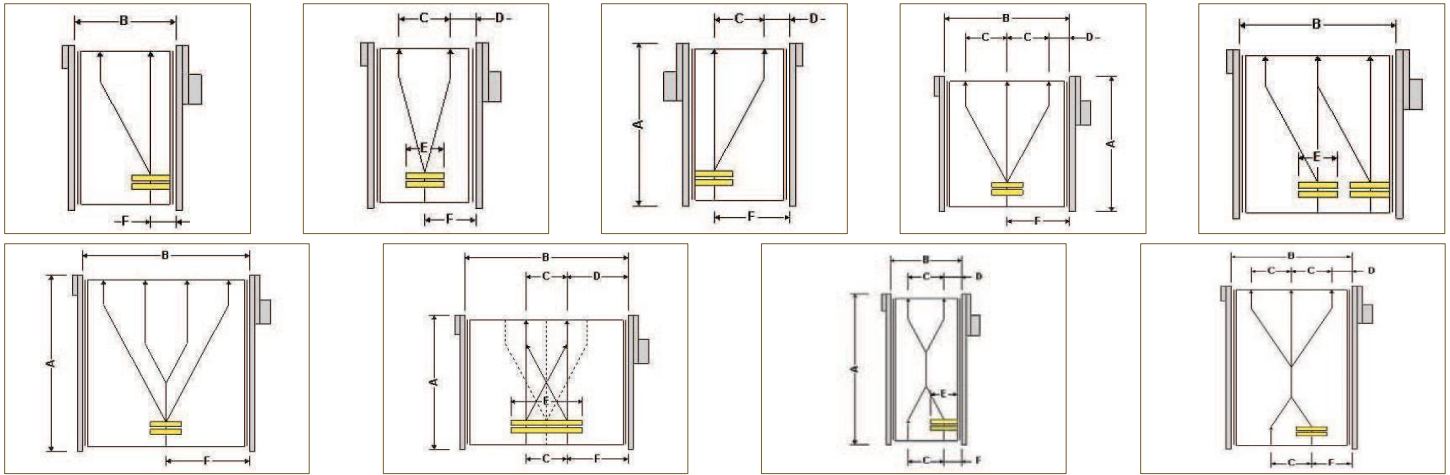

The frames for the Horizontal Switches are constructed of formed steel plate members. Product carriers are manufactured from ultra-high molecular weight (UHMW) plastic. The side chain is fully guarded on the top and ends, and a roller chain carries the cross rods, tubes and pallets. Stainless steel construction is available for non-caustic performance in wash-down environments. The switch may also be coated with a wide range of colors of industrial paint.

Model 550

- 199 fpm (1.88" ctrs.), 266 fpm (2.5" ctrs.)*
- 5#/ft.
- Standard 2" product carriers
- Spaced on 2.5" centers on the cross tubes
- A 50-pitch roller chain

Model 750

- 319 fpm (3.00" ctrs.), 425 fpm (4.00" ctrs.)*
- 40#/ft.
- Standard 3.5" product carriers
- Spaced on 4" centers on the cross tubes
- An 80-pitch roller chain.

Model 1000

- 318 fpm (3.00" ctrs.)*
- 100#/ft.
- Standard 2.5" product carriers
- Spaced on 3" centers on the cross tubes
- A 60-pitch roller chain

Model 1250

- 425 fpm (4.00" ctrs.)
- 100#/ft
- Standard 3.5" product carriers
- Spaced on 4" centers on the cross tubes
- An 80—pitch roller chain





Baker
THERMAL SOLUTIONS

NORTH CAROLINA

Baker Thermal Solutions
8182 Hwy 70 Bus West
Clayton, NC 27520
+1(919)674-3750
www.bakertherm.com

FOR MORE INFO, PLEASE CALL
(844) BAKE 411
OR VISIT OUR WEBSITES

 **THE MIDDLEBY CORPORATION**
PROCESSING & PACKAGING TECHNOLOGY BRANDS

 **STEWART
SYSTEMS**

TEXAS

Stewart Systems
808 Stewart Avenue
Plano, TX 75074
+1(972)422-5808
www.stewart-systems.com